

Export permission by the Japanese Government may be required for exporting our products in accordance with the Foreign Exchange and Foreign Trade Law. Please contact our sales office before exporting our products.

The specifications of this catalogue are subject to change without prior notice.

**TSUGAMI CORPORATION**

12-20, TOMIZAWA-CHO, NIHONBASHI,  
CHUO-KU, TOKYO 103-0006, JAPAN  
Phone : +81-3-3808-1172  
Facsimile : +81-3-3808-1175  
<http://www.tsugami.co.jp/>

# TSUGAMI

CNC Precision Automatic Lathe

## S205A-I S206A-I

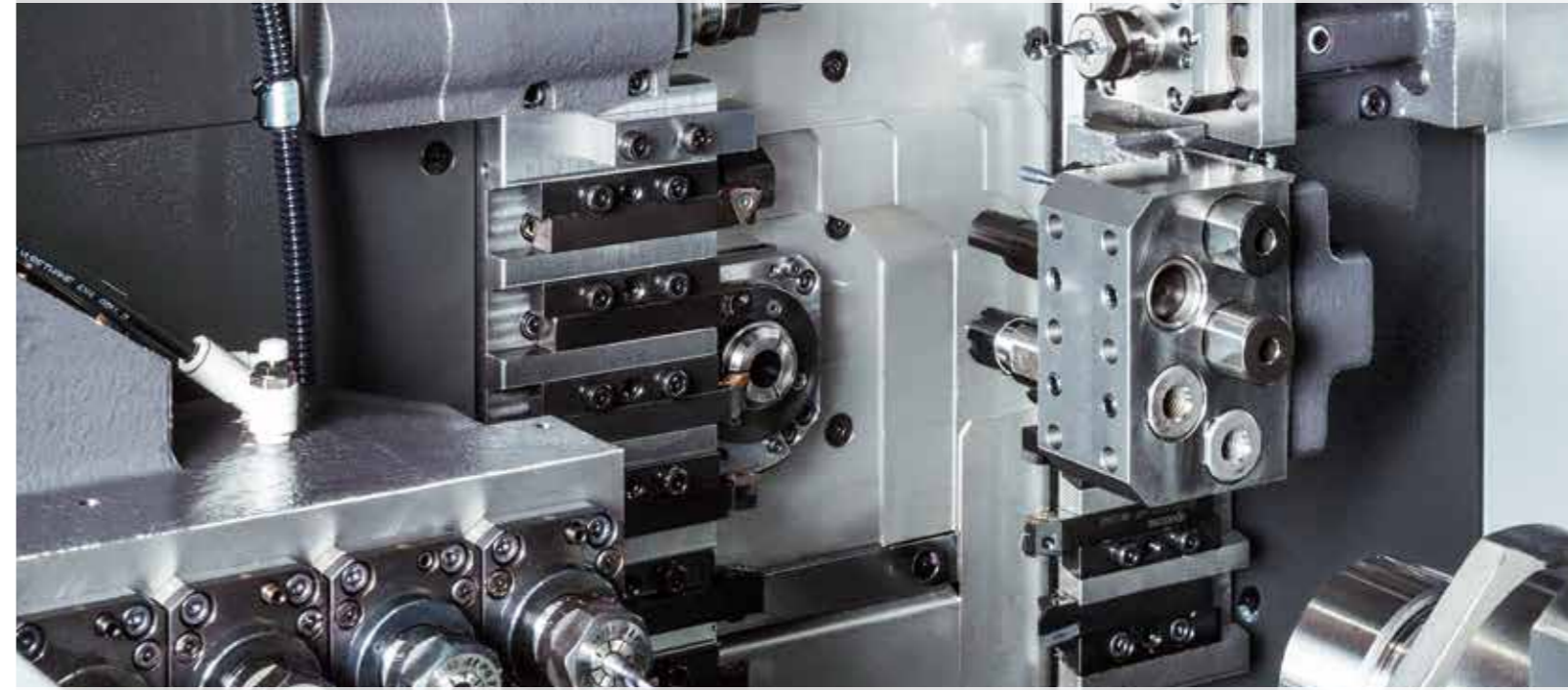

Enriched options realize suitable tooling according to diversified workpieces.



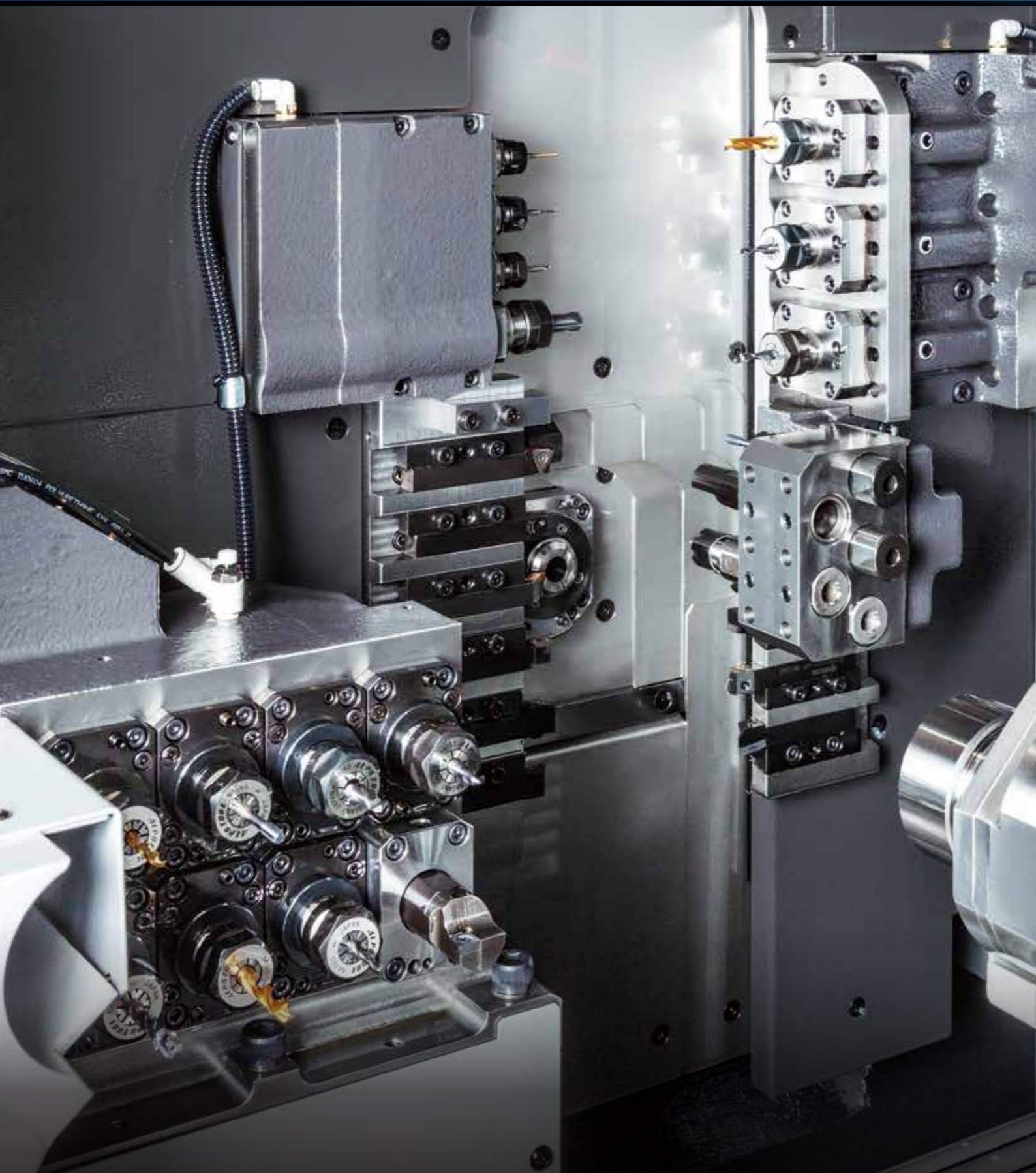

**Enriched options realize suitable tooling according to diversified workpieces.**

The simultaneous operation of back spindle side machining with main spindle side machining is feasible.

## S205A-II

Standard specification

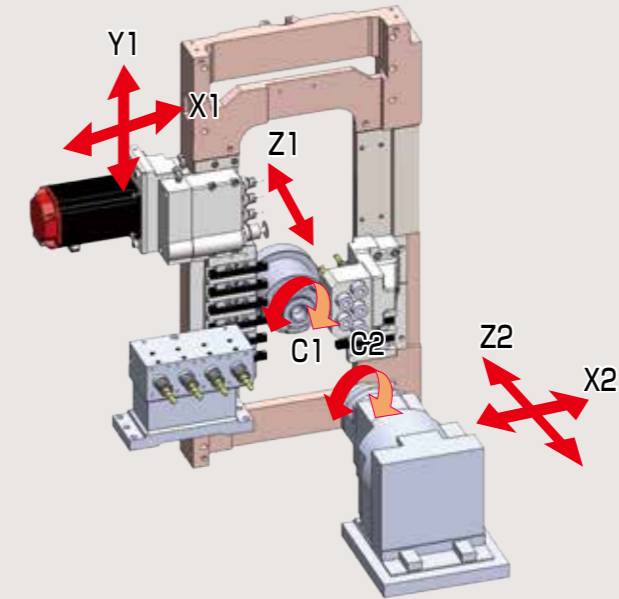

OD tool storage capacity	9	
Number of OD tools	4 to 7	
Number of front tools	Fixed	5 to 7
	Live	0 to 8
Number of back tools	Fixed	9
	Live	0 to 10
Total number of tools (Standard/Max.)	27/41	

The simultaneous operation of main spindle side machining with back spindle side machining including milling is realized by Y axis.

## S206A-II

Back tool post with Y-axis specification

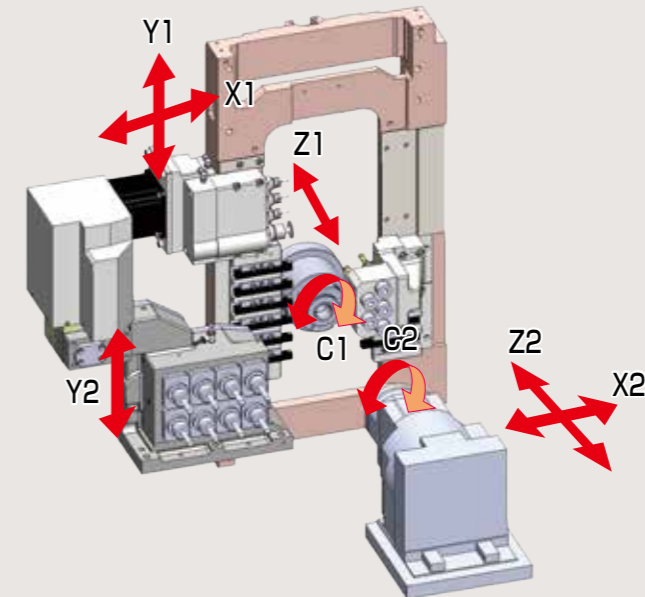

OD tool storage capacity	9	
Number of OD tools	4 to 7	
Number of front tools	Fixed	5 to 7
	Live	0 to 8
Number of back tools	Fixed	5 to 13
	Live	0 to 14
Total number of tools (Standard/Max.)	31/45	

# Modular tooling

Various arrangement of live tools, drill holders, and turning tools enables optimum tool allocation.

		S205A-II	S206A-II
Front tool post	Live tool of front tool post: 4 tools	○	○
Rear tool post	Rear drive: 3 tools	Option	Option
Back tool post	Back drill holder	○	—
	Back drive: 4 tools	Option	—
	Back drive: 8 tools	—	○
Deep hole tool post	Additional holder for back tool post *	—	Option
	Deep hole drill holder	Option	Option
	Live tool beside the back spindle: 2 tools	Option	Option

○ : Standard — : Not available  
 \* When mounting additional holder for back tool post, deep hole drill holder cannot be used.

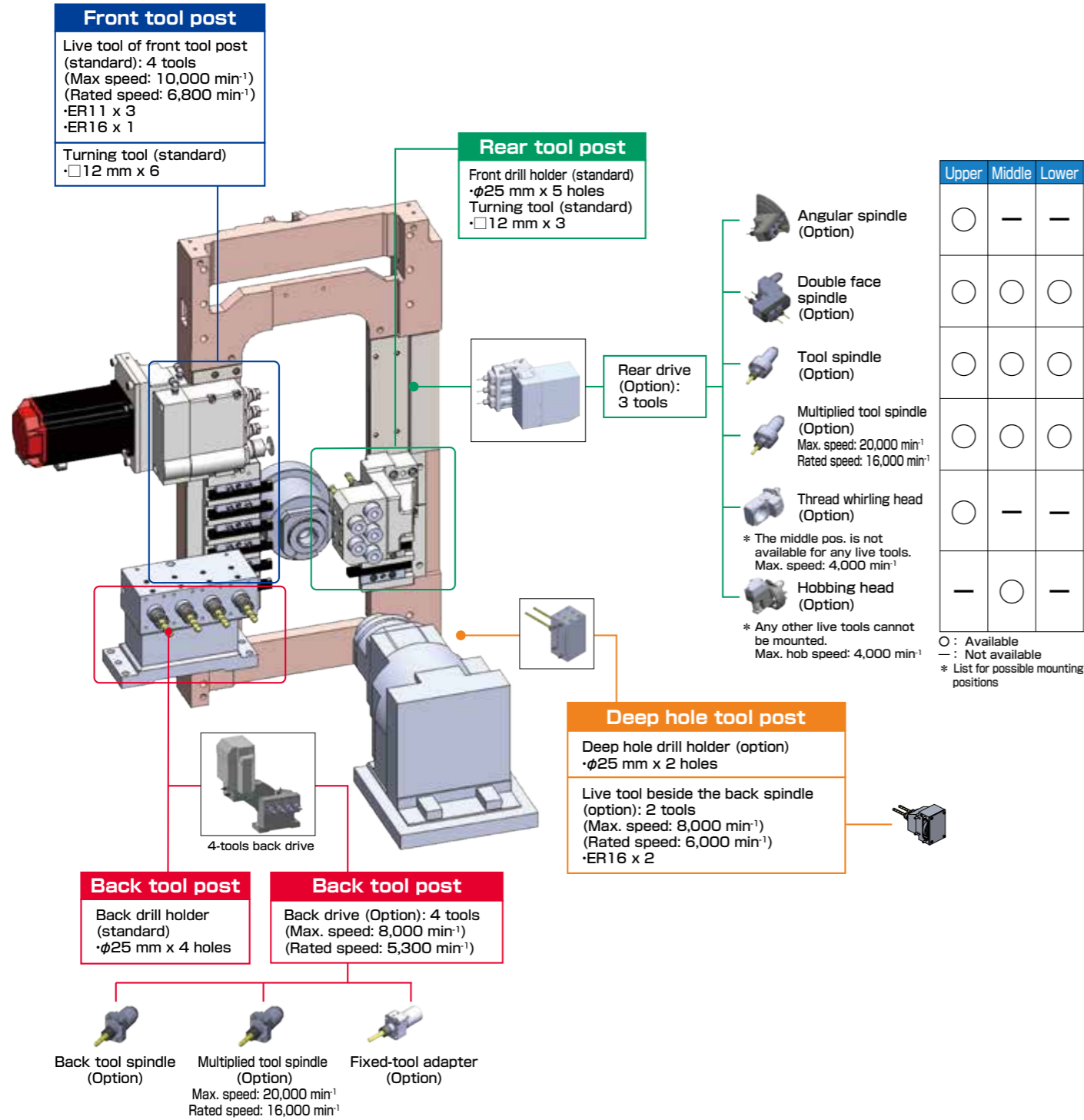

## S205A-II

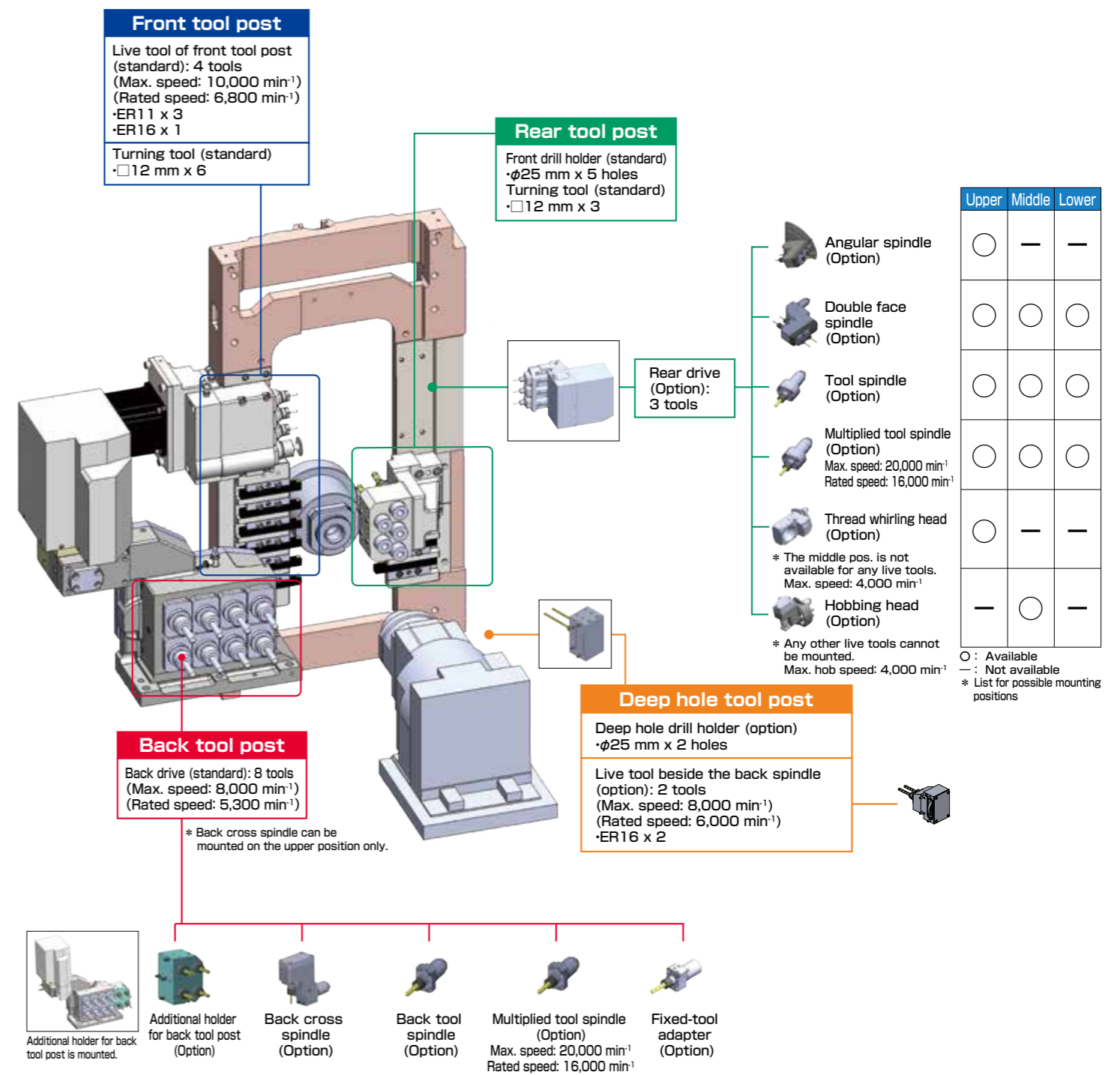

## S206A-II

# Modular tooling capability and various options allow the production of complicated workpiece.

Rear tool post drive and deep hole drill holder are available as option.  
Wide variety of specification.

■ Deep hole drill holder specification

Drill holder hole dia.	φ25 mm x 2 holes
Valid machining length	100 mm



Deep hole drill holder



Rear drive: 3 tools

## Tool post for the production of complicated work

- Rear drive (option): 3 tools
- Modular type live tools can be installed in 3 positions.

Modular type live tools	
Tool spindle	
Double face spindle	
Angular spindle	
Thread whirling head	

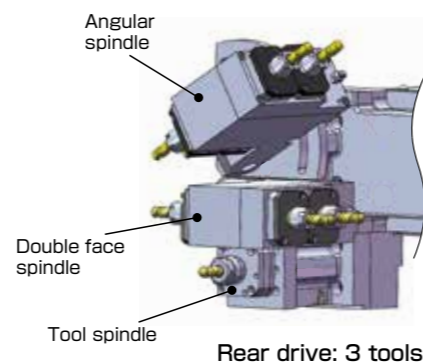

Rear drive: 3 tools

- Back drive: 8 tools (S206A-II)
- Enables the simultaneous operation of back spindle side complex machining with main spindle side machining.
- Meets the needs of back spindle side complex machining.
- Maximum 8 modular type live tools can be installed.

Modular type live tools	
Back tool spindle	
Back cross spindle	
Multiplied tool spindle	
Fixed-tool adapter	

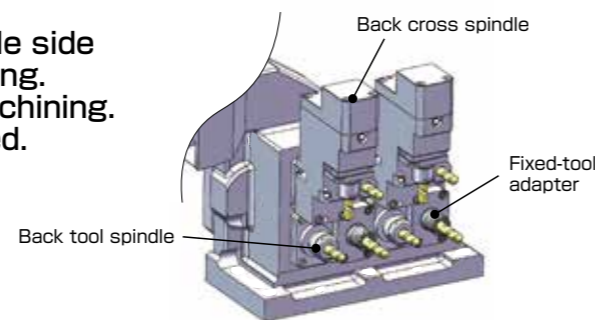

Back drive: 8 tools

## Optional direct-drive guide bushing provides high-speed and accurate machining.

- Max. speed: 10,000 min<sup>-1</sup> (Rated speed: 8,000 min<sup>-1</sup>)
  - Max. machining length: 210mm
- The stable geometrical accuracy, the dimensional accuracy, and the surface roughness are secured by the quiet operation even on high speed.

Guide-bushing type or guide-bushless type is selectable according to the workpiece (option).

- Possible to switch between the guide-bushing type and guide-bushless type. Most suitable system for the workpiece can be chosen.
- The guide-bushless type does not require ground bars, and enables high speed and high precision machining from inexpensive cold-drawn bars.

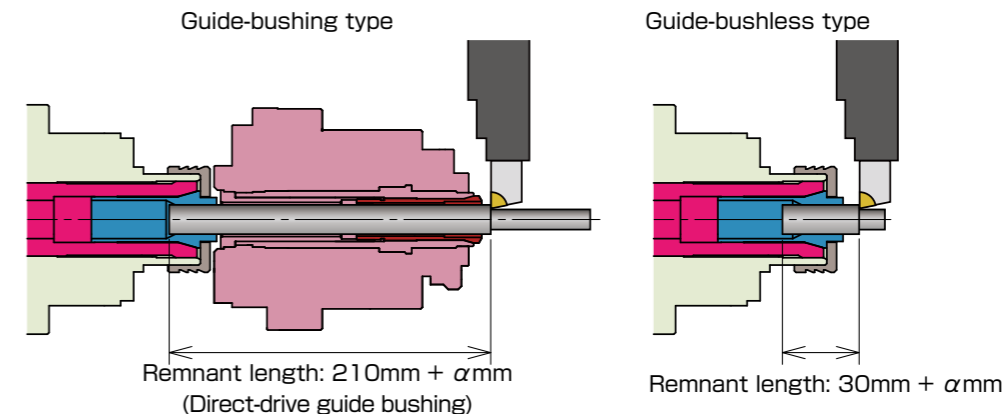

# Creates programs easily and quickly for complicated workpieces.

Minimized tool change time with the optimized tool path by PC-based automatic programming software.

The program created by the automatic programming software allows an optimum matching of all paths and shortens the cycle time. The 3D simulation enables the user to check the operations of main/back spindles from any angle. With TSUGAMI's know-how (machining process and cutting conditions), high quality and standardized programs can be created.

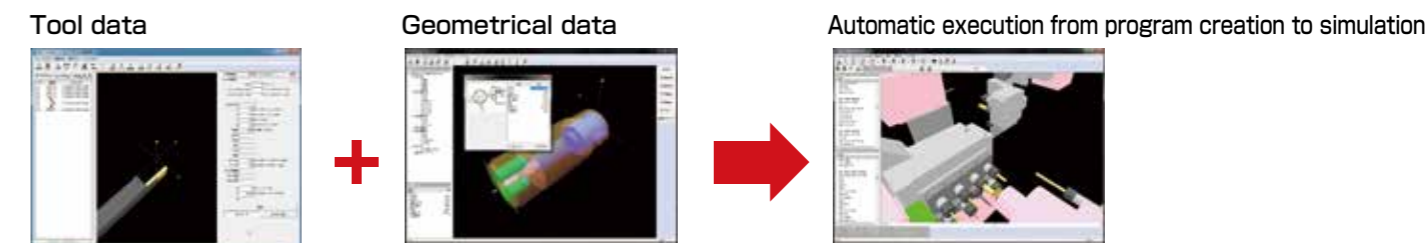

Input the tool data and the geometrical data.

# Option



**Angular spindle**  
Used for inclined drilling.  
●3282-Y3922



**Back cross spindle**  
Used for cross drilling of back side.  
(Not available for S205A-II.)  
●3290-Y3041



**Thread whirling head**  
Used for machining of bone screws and long screws.  
●3281-Y2451

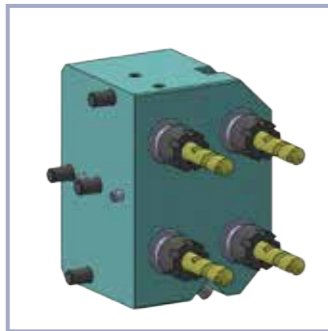

**Additional holder for back tool post**  
φ25mm x 4 holes are added for multiplied complicated on back spindle side.  
\*When mounting additional holder for back tool post, deep hole drill holder cannot be used.  
(Not available for S205A-II.)  
●3290-Y3031

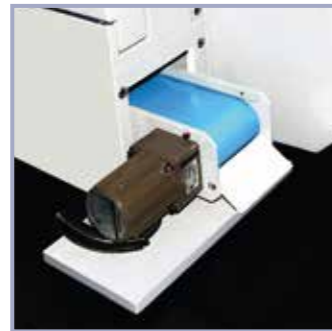

**Work conveyor**  
After receiving an ejected workpiece from the back spindle with the work catcher, the work conveyor carries the workpiece to the machine right outside.  
●3290-Y13060



**Work catcher**  
The workpiece is discharged from back spindle into the chute of the catcher, and carried out to the work conveyor.  
●3290-Y3070



**Direct-drive guide bushing**  
Used for long workpiece machining. The stable geometrical accuracy, the dimensional accuracy, and the surface roughness are secured by the quiet operation even on high speed.  
●3281-Y2010



**Chip conveyor**  
This unit carries the chips to right side of the machine. Curled and long chips can be handled by this hinge type conveyor.  
●3290-Y3960



**Wavy nozzle**  
The discharge angle can be adjusted arbitrarily. Chips are guided in one direction and it contributes to preventing the jam of chips. Swivel angle and moving speed can be adjusted.  
●3290-Y3400

## Machine specifications

Item	S205A-II	S206A-II	
Machining range, Machine capacity	Bar stock chucking dia.	φ3 mm to φ20 mm	
	Max. back spindle chucking dia.	φ20 mm	
	Max. machining length	210 mm (Direct-drive rotary guide bushing*1)	
		250 mm (Stationary guide bushing*1)	
		80 mm (Carrier type rotary guide bushing*1)	
		45 mm (Guide-bushless*1)	
	Max. main spindle drilling dia.	φ12 mm	
	Max. main spindle tapping dia.	M10	
	Max. back spindle drilling dia.	φ12 mm	
	Max. back spindle tapping dia.	M10	
	Max. deep hole drilling dia.*1	φ8 mm	
	Max. live tool drilling dia.	φ8 mm (Front tool post / Rear tool post*1 / Back tool post*2)	
	Max. live tool tapping dia.	M6 (Front tool post / Rear tool post*1 / Back tool post*2)	
Max. live tool slotting cutter dia.	φ30 mm (Front tool post: T04)		
Machine	Main spindle speed	Max. 10,000 min <sup>-1</sup> (Rated speed: 8,000min <sup>-1</sup> )*3	
	Back spindle speed	Max. 10,000 min <sup>-1</sup> (Rated speed: 8,000min <sup>-1</sup> )*3*4	
	Rotary guide bushing speed *1	Max. 10,000 min <sup>-1</sup> (Rated speed: 8,000 min <sup>-1</sup> ) (Direct-drive)*1*3	
	Live tool speed	Max. 10,000 min <sup>-1</sup> (Rated speed: 6,800 min <sup>-1</sup> )*3 (Front tool post)	
		Max. 8,000 min <sup>-1</sup> (Rated speed: 5,300 min <sup>-1</sup> )*3 (Rear tool post*1 / Back tool post*2)	
	Tool storage capacity	27	31
Tool size	□12 mm		
Rapid traverse rate	35 m/min (X1, Y1, Y2: 24 m/min) (Y2 axis is only for S206A-II.)		
Motors	Main spindle	2.2/3.7 kW	
	Back spindle	2.2/3.7 kW	
	Linear axes	0.5 kW(X1, Y2) 0.75 kW(Y1, Z1, X2, Z2) (Y2 axis is only for S206A-II.)	
	Live tool	1.0 kW (Front tool post / Rear tool post*1 / Back tool post*2)	
	Coolant pump	0.4 kW	
	Lubricating oil pump	3 W	
Power supply and others	Weight	3,750 kg	
	Power source requirement	12.1 kVA	
	Compressed air requirement	0.4 MPa or above	
	Air discharge rate	100 NL/min	
	Coolant tank capacity	180 L	
	Width x Depth x Height	2,325 mm x 1,270 mm x 1,970 mm	

\*1 Option  
\*2 Option only for S205A-II.  
\*3 The rotation more than the rated speed should be short period.  
\*4 When the live tool beside the back spindle (option) is used, the maximum back spindle speed is restricted to 8,000 min<sup>-1</sup>.

## NC Specifications

Item	S205A-II	S206A-II
Controlled axes	X1, Z1, Y1, X2, Z2, C1, C2	X1, Z1, Y1, X2, Z2, Y2, C1, C2
Least input increment	0.001 mm (X1/X2-axis in diameter) / 0.001°	
Max. programmable value	±8 digits	
Interpolation method	Linear, Circular	
Feedrate	1 to 6,000mm/min	
Feedrate override	0 to 150% in 10% increments	
Dwell	G04 0 to 99999.999	
Absolute/incremental command	X, Z, Y, C: Absolute, U, W, V, H: Incremental	
Number of tool offset	Main: 64, Back: 64	
LCD/MDI	10.4" color LCD	
Display language	Japanese / English	
Part program storage size	2 Mbyte (sum of main and back)	
Number of registerable programs	1,000 (sum of main and back)	
Miscellaneous functions	Main: M5-digits, Back: M3-digits	
Spindle functions	S5-digits	
Tool functions	T4-digits	

Machine standard accessories

Item	Item
Live tool of front tool post: 4 tools	Spindle cooling unit
Back drive: 8 tools (S206A-II)	Standard tools
Front drill holder	Transit clamps
Back drill holder (S205A-II)	Automatic power shut off
C-axis control for main/back spindles	Main/back spindle air purge
Automatic programming software	Live tool air purge
Tool height compensation	Main spindle brake
Tool counter	Automatic cut-off function / Automatic facing function
Periodic maintenance screen	Internal illumination lamp (Tooling zone)
Main/back spindle adapter	Thermal displacement compensation
Door interlock (Tooling zone/Headstock area)	Retractable coolant nozzle
Coolant level switch	

NC standard accessories

Item	Item
Chasing function	Extended program editing
Continuous thread cutting	Canned drilling cycle
Manual pulse generator	Rigid tap (Main spindle, back spindle, live tool)
Memory card I/O interface	Cut-off detection (Speed differential type)
Background editing	Spindle speed fluctuation detection
Run time & parts number display	Tool load monitor (live tool)
Custom macro	HRV control
Constant surface speed control	Fixed data setting screen
Spindle synchronous control (rotation/phase)	Direct drawing dimension program
Z1-Z2 synchronous control	Polar coordinate interpolation
Tool geometry / Wear offset	Cylindrical interpolation
Programmable data input	Variable-lead thread cutting
Chamfering & Corner R	Thread cutting cycle retract
Tool nose radius compensation	Inch/metric conversion
Multiple repetitive cycle	

Options

Item	Item	Item	Item
Guide bushing	Stationary guide bushing	Live tools (Back tool post)	Back cross spindle (S206A-II)
	Carrier type rotary guide bushing		Fixed-tool adapter
	Direct-drive rotary guide bushing		Live tool beside the back spindle: 2 tools
	Guide-bushless		High pressure pump
Spindle functions	Back spindle brake	Coolant	M code oil blow
	Back spindle 15 deg index		Wavy nozzle
High accuracy functions	0.1 μm resolution	Work discharge	Work conveyor
	Coolant temperature controller		Work catcher
	Touch switch for X2 axis		Front discharge
Live tools (Rear tool post)	Rear drive: 3 tools (Modular type)	Chip disposal	Rear discharge
	Tool spindle		Work tray
	Multiplied tool spindle		Work unloader
	Double face spindle	Machine maintenance and monitoring functions	Chip conveyor
	Angular spindle		Chip carrier
	Multiplied face spindle head		Tool load monitor (both spindles)
	Multiplied angular spindle head		Signal indicator
Triple face spindle	Safety and other	Collet chuck with carbide lining	
Thread whirling head		Thread whirling holder	
Hobbing head		Drill holder	
Live tools (Back tool post)	Back drive: 4 tools (Modular type) (S205A-II)	Tooling	Deep hole drill holder (φ25mm x 2 holes)
	Back tool spindle		Additional holder for back tool post (S206A-II)
	Multiplied tool spindle		Spindle liner

Tooling zone

S205A-II

Direct-drive rotary GB (option)

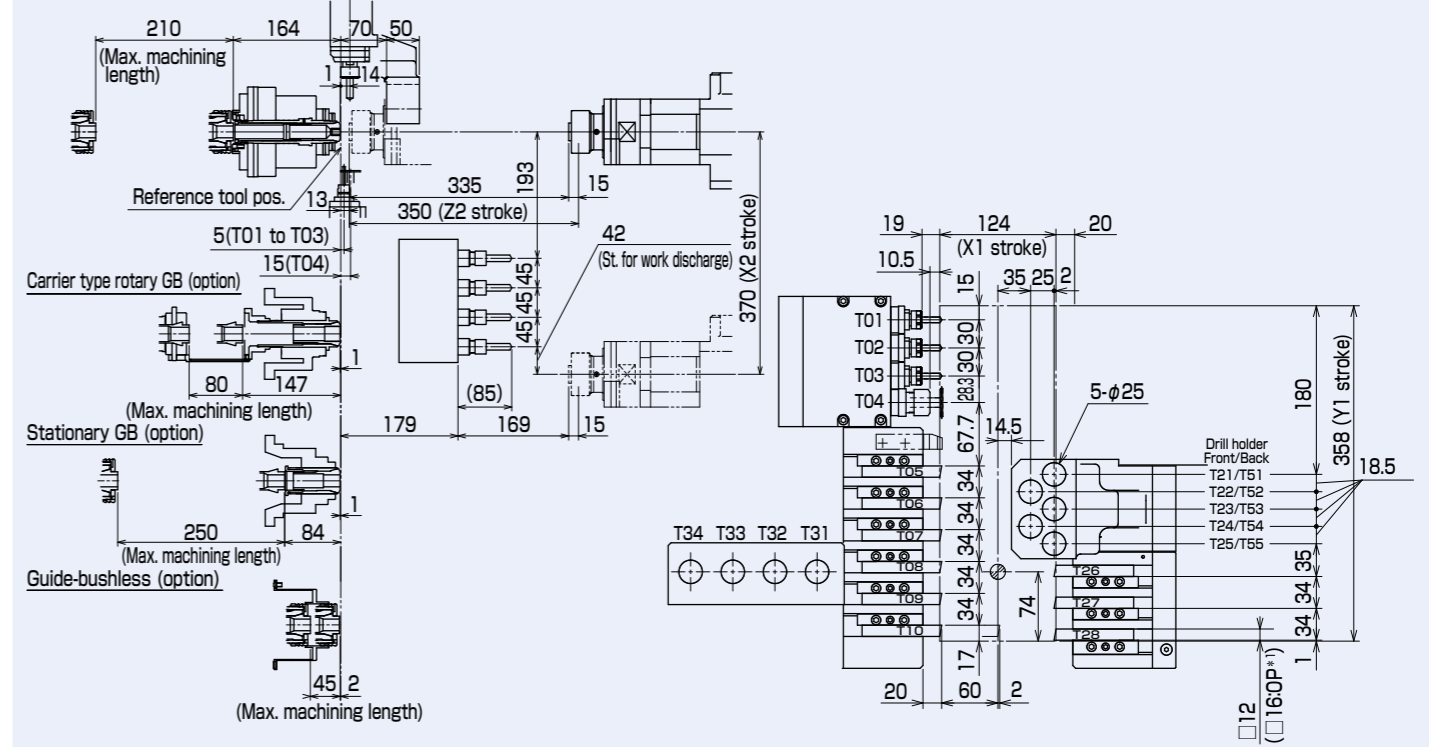

S206A-II

Direct-drive rotary GB (option)

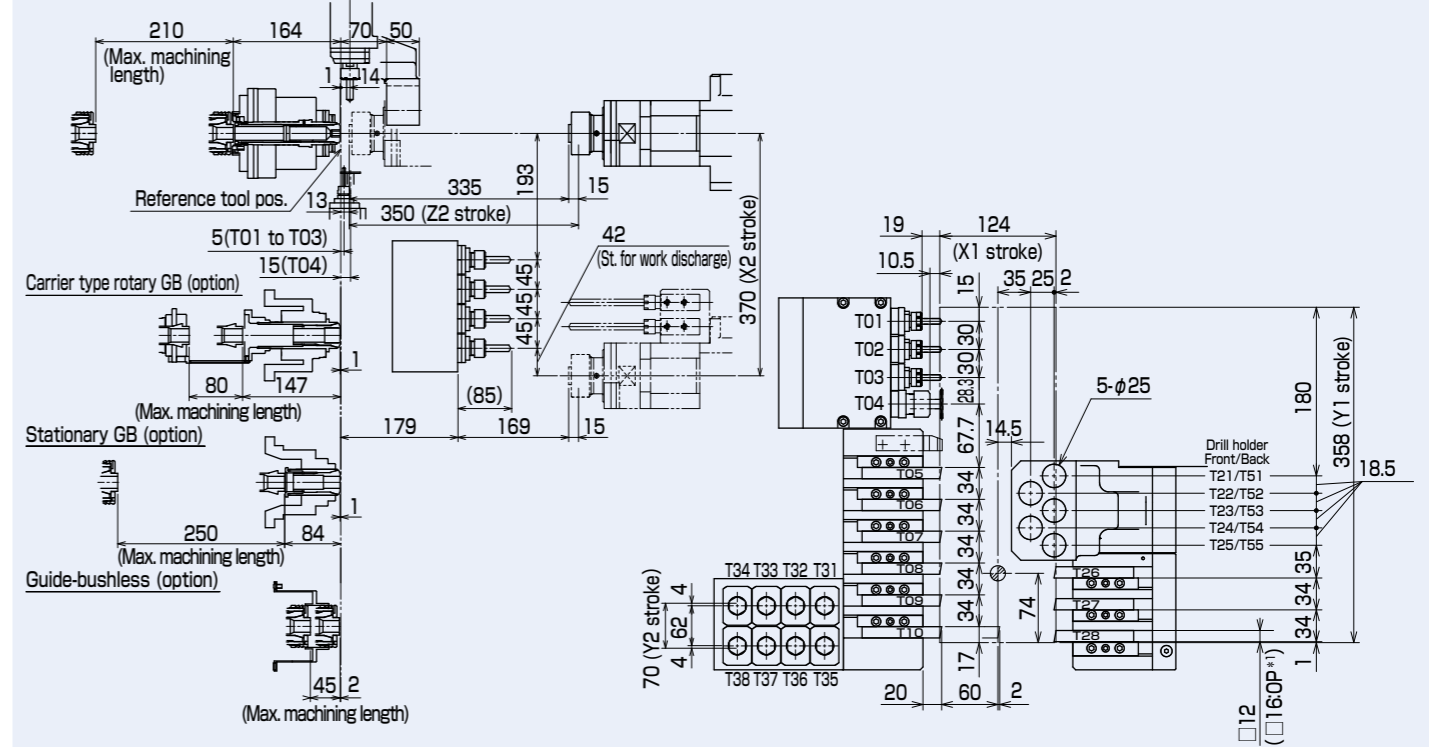

\*1 Number of mountable tools and tool distance are same on □16 mm tool post.  
\*2 When mounting the work catcher, X2 and Z2 strokes are limited to prevent interference with back spindle.