

Muratec New Standard - 6 inch size Bar Turning Machine



Features

Specialized for processing bar workpieces, equipped with 2 spindles, 2 turrets, live tools, and a Y-axis function (upper turret only). Achieves a high degree of versatility while maintaining a simple structure.

- Provides both cost performance and flexibility
- Equipped with Muratec's latest thermal displacement correction system to achieve even more stable operation
- High power spindle motor, high power live tool specification is also available
- FANUC MANUAL GUIDE i is equipped as standard

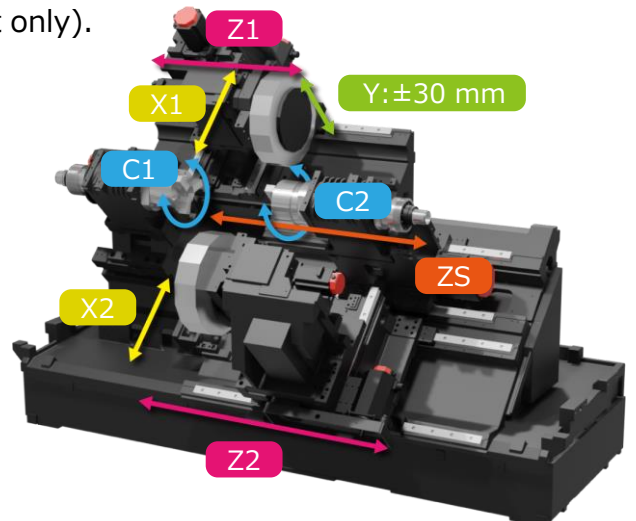

*MANUAL GUIDE is registered trademark of FANUC CORPORATION in Japan and other countries.

Specifications

Available in a total of 3 different specification patterns through different combinations of bar material diameter, spindle motor, number of tools (turret specification), and live tool output. Can be selected based on the materials being processed.

■ Standard Type

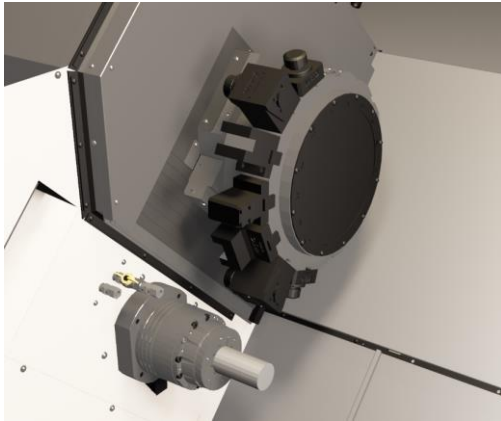

■ Big Bore/ High Power Spindle and Live Tool Type

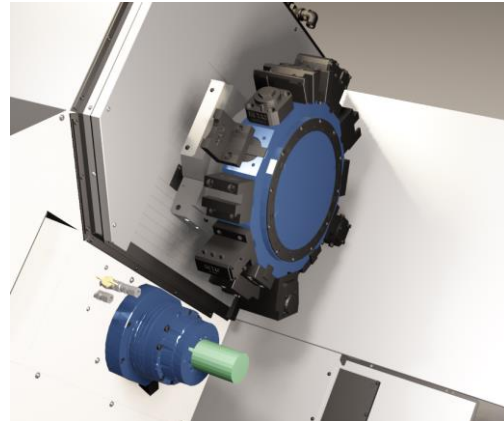

		Standard Type (MT1051)	Big Bore Spindle Type (MT1065)	Big Bore / High Power Spindle and Live Tool Type (MT1065EX)
Chuck Size		6 inch (ø165 mm)	6 inch (ø165 mm)	6 inch (ø165 mm)
Number of Turret Stations		15 × 2	15 × 2	12 × 2 *
Max. Bar Diameter		ø51 mm	ø65 mm	ø65 mm
Spindle Drive Motor	Left	11 kW/15min	15 kW/15min	18.5 kW/15min
	Right	7.5 kW/15min	11 kW/15min	15 kW/15min
Max. Spindle Speed	Left	6,000 min ⁻¹	4,500 min ⁻¹	4,500 min ⁻¹
	Right	6,000 min ⁻¹	6,000 min ⁻¹	6,000 min ⁻¹
Live Tool Motor		12.0 kW/Max. (2.2 kW/cont.)	12.0 kW/Max. (2.2 kW/cont.)	22.0 kW/Max. (2.2 kW/cont.)
Tool Clamping	O.D.Tool	□20 mm	□20 mm	□20/25 mm
	I.D.Tool	ø25 mm	ø25 mm	ø25/32 mm

*Can be equipped with a maximum of 24 tools with the turret half index function

Floor Plan

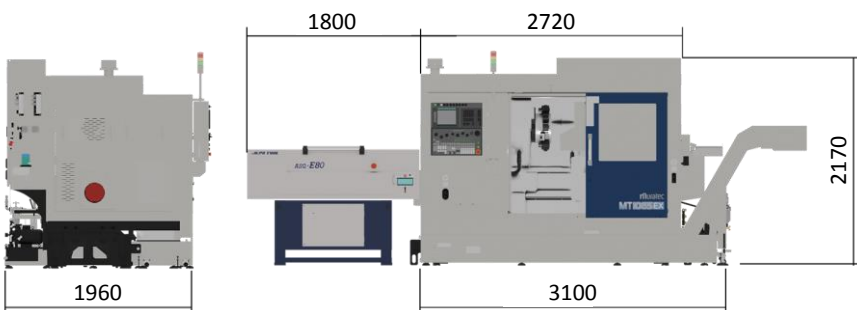

Chip Conveyor: Right / Rear Discharge available
 * A bar feeder is an optional item.

• **Safety Specification**
 For EU countries, machines are built with CE-safety conformity.

* The machines shown in the catalogue include some optional items and may vary in appearance from the actual machines.
 * Specifications and designs are subject to change without prior notice.

MURATA MACHINERY, LTD.
MACHINE TOOLS DIVISION



Network